



The Audi Q8 e-tron





The power of electric mobility

The Audi Q8 e-tron makes a clear statement that it is an advanced model in the electric SUV range, featuring plug-in and fast-charging convenience, advanced energy recuperation whilst driving and zero emissions. An electrified Audi is a leap into smarter driving with sophisticated batteries, the pioneering charging application "ChargeMyAudi", a first of its kind in the industry, guarantees a delightful and trouble-free journey experience.





Electrifying performance

Powered by two incredibly dynamic electric motors in the front and rear, the Audi Q8 e-tron is a completely novel driving experience. This electric SUV promises an impressive driving experience with its progressive steering and all-wheel drive system which provides optimal traction and handling in all driving situations.



Audi Q8 50 e-tron

Performance



Electrical Power
250 kW/340 hp



Torque
664 Nm



Acceleration
6.0 sec
(0 to 100 km/h)



**Range
(WLTP combined)***
491 km



Battery
95 kWh



Audi Q8 55 e-tron

Performance



Electrical Power
300 kW/408 hp



Torque
664 Nm



Acceleration
5.6 sec
(0 to 100 km/h)



**Range
(WLTP combined)***
582 km



Battery
114 kWh

*This maximum value is obtained in efficiency driving mode on 48.26 cm tires with air conditioning and heating switched off within city conditions at a temperature above 5°C as per the WLTP certificate. Driving range may vary for other driving conditions and environment factors.



Audi Q8 Sportback 50 e-tron

Performance



Electrical Power
250 kW/340 hp



Torque
664 Nm



Acceleration
6.0 sec
(0 to 100 km/h)



**Range
(WLTP combined)***
505 km



Battery
95 kWh

*This maximum value is obtained in efficiency driving mode on 48.26 cm tires with air conditioning and heating switched off within city conditions at a temperature above 5°C as per the WLTP certificate. Driving range may vary for other driving conditions and environment factors.



Audi Q8 Sportback 55 e-tron

Performance



Electrical Power
300 kW/408 hp



Torque
664 Nm



Acceleration
5.6 sec
(0 to 100 km/h)



**Range
(WLTP combined)***
600 km



Battery
114 kWh

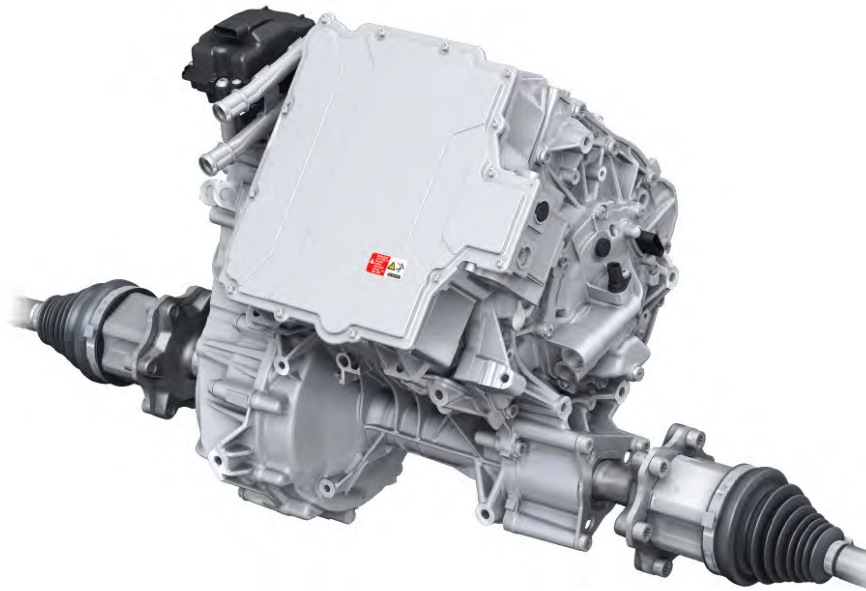

Performance features

Front and Rear electric motors

Two electric motors in the front and rear means that the Audi Q8 e-tron comes with effortless power. An electric boost in the Audi Q8 e-tron provides a surge in power to improve the acceleration and can be activated via a kick-down pedal while in dynamic mode or transmission in S mode.

Progressive Steering System

Progressive steering is a standard feature in the Audi Q8 e-tron that enhances handling dynamics and ride comfort. This steering assistance system provides more direct steering and reduces steering effort which makes your Audi Q8 e-tron more responsive in the city for easy parking and maneuvering, more agile and precise on open roads.

e-quattro All-wheel drive

The Audi Q8 e-tron is equipped with a fully variable quattro drive as standard. Working together with the electric drive system, it ensures that drive forces are distributed quickly and as required to each individual wheel. The quattro drive in the Audi Q8 e-tron consequently excels in driving dynamics, traction, safety and efficiency.





Performance features

Audi Drive Select

The Audi drive select comes pre-loaded with 7 different modes that allow you to adjust the vehicle's characteristics by adapting the steering assistance, engine characteristics and adaptive air suspension.

Adaptive Air Suspension

The standard adaptive air suspension system sets the height of the body at different levels depending on the vehicle's speed and the driver's request. This means that the Audi Q8 e-tron intuitively increases or decreases its ground clearance, thereby providing supreme ride comfort and sporty handling.





Elegantly electric

An unmistakable driving feeling, the Audi Q8 e-tron comes straight from the future with a perfect balance between dynamics and comfort. Electrifying your everyday lifestyle with its exhilarating performance and elegance, it offers exquisite comfort when driving through the city, on the highway and even on winding mountain roads.



Exterior features

Digital Matrix LED Headlights*

The Audi digital matrix LED headlights are based on the cutting-edge digital micromirror device technology. This revolutionary technology opens up new possibilities for adaptive light distribution and light assistance through the direct projection of high-resolution light images. It automatically adjusts the orientation of the light, thereby dimming and illuminating the road ahead as needed. The Audi Q8 e-tron also offers 5 pre-set projection modes to animation.

Rear Lights With Continuous LED Strips

This aesthetic feature accentuates the shape of your Audi Q8 e-tron. The continuous LED strips in the rear make the design more dynamic, and your vehicle more visually stunning.





Exterior features

Soft Door Closing*

The power-assisted door closing function gently pulls the doors in and closes them soundlessly.

Charging Inlet On Both Sides

Recharging the Audi Q8 e-tron becomes easier and convenient when the charging slots are available on both sides of the car. Park the vehicle in any direction to charge it.





Exterior features

Singleframe Projection Light

Elevating Audi's legendary logo to new heights of prominence at the front. The enhanced Singleframe Projection Light spoiler elegantly accentuates the four rings as the centerpiece, exemplifying the essence of true luxury.

Comfort Key With Gesture-based Lid Operation

Unlocking the Audi Q8 e-tron is now easier with the convenience of the comfort key. You simply need to carry the comfort key with you and the system lets you unlock your vehicle. And when your hands are full, a simple foot gesture can open, and close, your Audi Q8 e-tron's boot lid with ease.





Interior features

Wraparound Dash Panel

The wraparound dash panel gracefully traces the arc of the car, encompassing the instrument panel and harmoniously integrating the hood above the Audi virtual cockpit plus.

4-zone Climate Control System with Air ionizer and Aromatization

A standard feature of the Audi Q8 e-tron, the 4-zone climate control system with air ionizer and aromatization takes interior air quality to a whole new level. Two ionizers charge the air molecules electrically with negative ions. It presents a choice of two fragrances and four intensity levels for top-notch air quality customization.

360-degree Camera System

Four wide-angle 360-degree cameras provide a range of different views as you manoeuvre your Audi Q8 e-tron. These cameras cover the area immediately around your vehicle and can be controlled via the top MMI display.





Infotainment features

Audi Virtual Cockpit Plus

Innovative. Adaptive. Intuitive. The Audi virtual cockpit plus is a 31.24 cm fully digital instrument cluster. Designed for the flexible, on-demand display of relevant information, it is tailored to fit the driver's needs, from monitoring electric range to displaying maps, to connecting with the radio and media services. It has 3 individual display options: 'e-tron', 'Sport' and 'Classic', each with 2 different-sized displays of the round instruments.

Bang & Olufsen Premium 3D Sound System

The B&O Premium sound system with 3D sound offers an exceptional sound experience, featuring a 15-channel amplifier with a total output of 705 watts and 16 speakers. It creates a virtually unrivaled authentic 3D sound experience in the vehicle, giving the impression that you are sitting in the front row of a concert hall.

Audi Phone Box with Wireless Charging

The Audi phone box with wireless charging is an important feature for those on the go. It optimises phone calls in the vehicle, thanks to its improved reception and call quality along with wireless charging.





Efficiency and charging

Entering the new era of progress, the electrifying Audi Q8 e-tron comes with significantly increased battery capacity and charging performance, allowing an optimal balance between energy density and charging capacity, as well as increased efficiency.

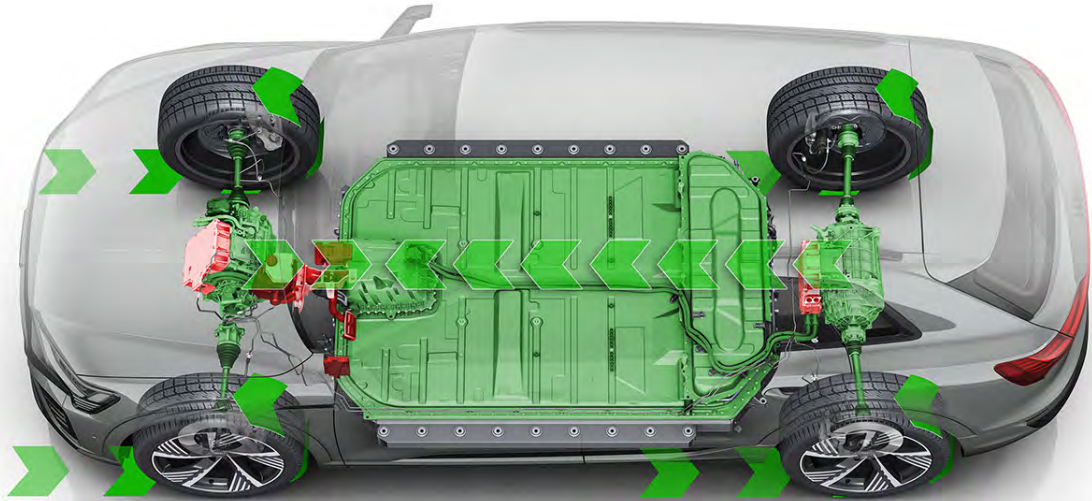

Charging features

Thermal Management System

The Audi Q8 e-tron's thermal management system is responsible for heating up and cooling down the battery in response to the ambient temperature, optimising battery longevity and ensuring reproducible performance. The thermal management system makes DC charging up to 170 kW possible due to its intelligent cooling capabilities.

Recuperation

With its ground-breaking recuperation technology, the Audi Q8 e-tron converts kinetic energy into electrical energy. 3 selectable recuperation stages allow you to adapt recuperation to your individual requirements, with each stage having a different level of deceleration that lets you recover different amounts of energy. This system can be controlled manually using shift paddles too.

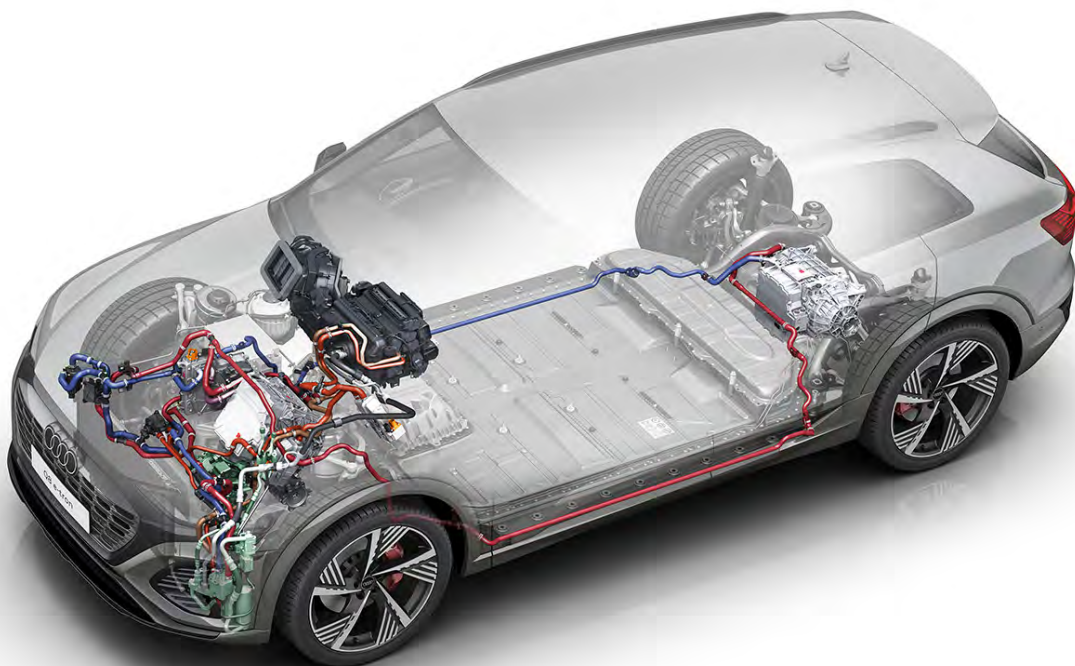



Charging capacity

11 kW AC Charging

The Audi Q8 e-tron can be charged at home or at the office using the 11 kW AC compact charging system. Overnight charging can set you up with a full battery for the next day.

22 kW AC Charging

The Audi Q8 e-tron also provides an optional 22 kW on-board charger, that can be used at public AC charging stations and Audi dealerships. This cuts down your charging time by half, when compared to the 11 kW AC charger.

170 kW DC Charging

Leave your charging concerns at home when driving long distances. Audi Q8 55 e-tron can be charged with up to 170 kW at high-output DC charging stations. This allows you to charge up to 80% of your battery in just 30 mins. Audi Q8 50 e-tron can be fast charged when charged with up to 150 kW DC charging.



Exterior colour options

Choose the best shade for your Audi Q8 e-tron and Audi Q8 Sportback e-tron from these exterior colour options.



Chronos Gray (M)

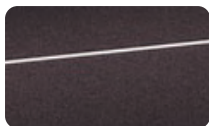

Madeira Brown (M)



Glacier White (M)



Mythos Black (M)



Plasma Blue (M)



Soneira Red (M)



Magnet Gray (S)



Siam Beige (M)*



Manhattan Gray (M)*

*exterior color is only available with contrast paint finish.



Interior colour options

Select the best hue for the interiors.

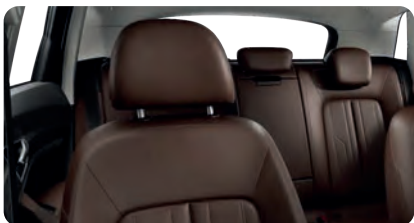

Okapi Brown



Black



Pearl Beige

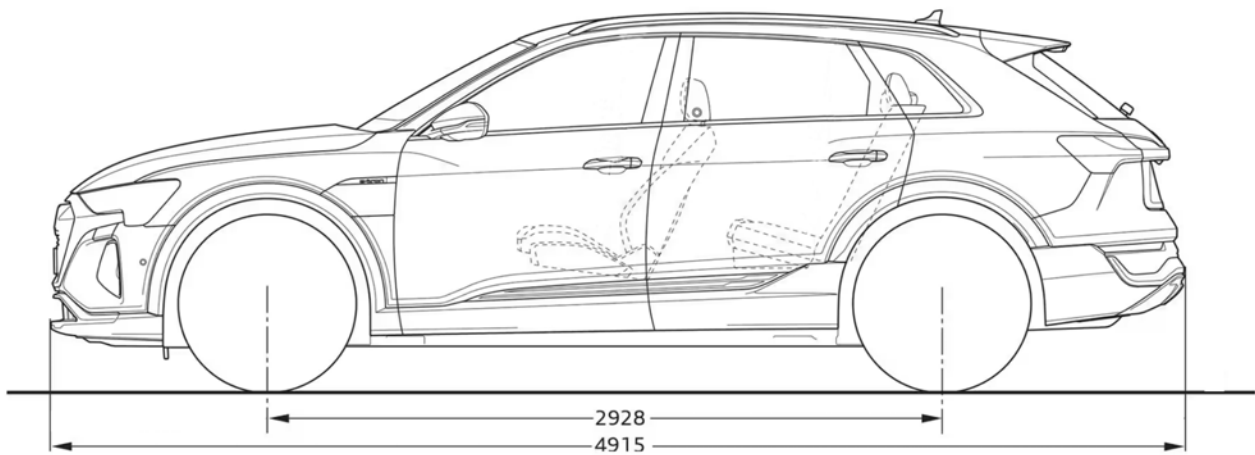
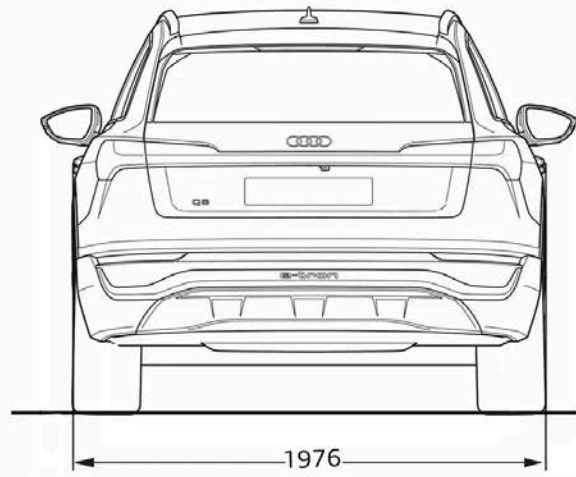
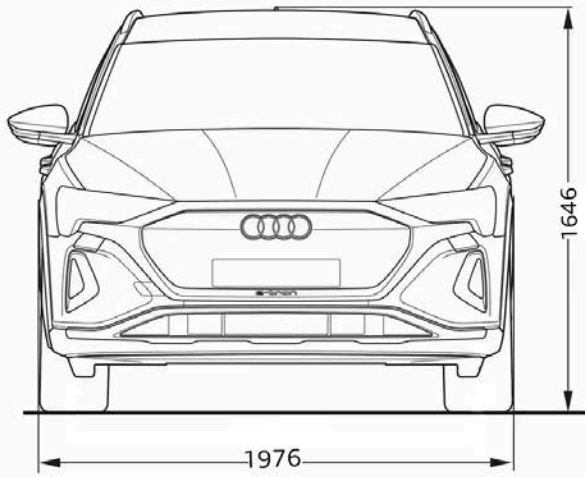

Technical details

Audi Q8 50 e-tron

Power (hp at rpm)
340

Torque (Nm)
664

Acceleration (0-100 Kilometers per hour)
6.0

Top Speed (Kilometers per hour)
200

Drive Type
quattro

Dimensions LxWxH (mm)
4915 x 1976 x 1646

Wheel Base (mm)
2928

Audi Q8 55 e-tron

Power (hp at rpm)
408

Torque (Nm)
664

Acceleration (0-100 Kilometers per hour)
5.6

Top Speed (Kilometers per hour)
200

Drive Type
quattro

Dimensions LxWxH (mm)
4915 x 1976 x 1646

Wheel Base (mm)
2928

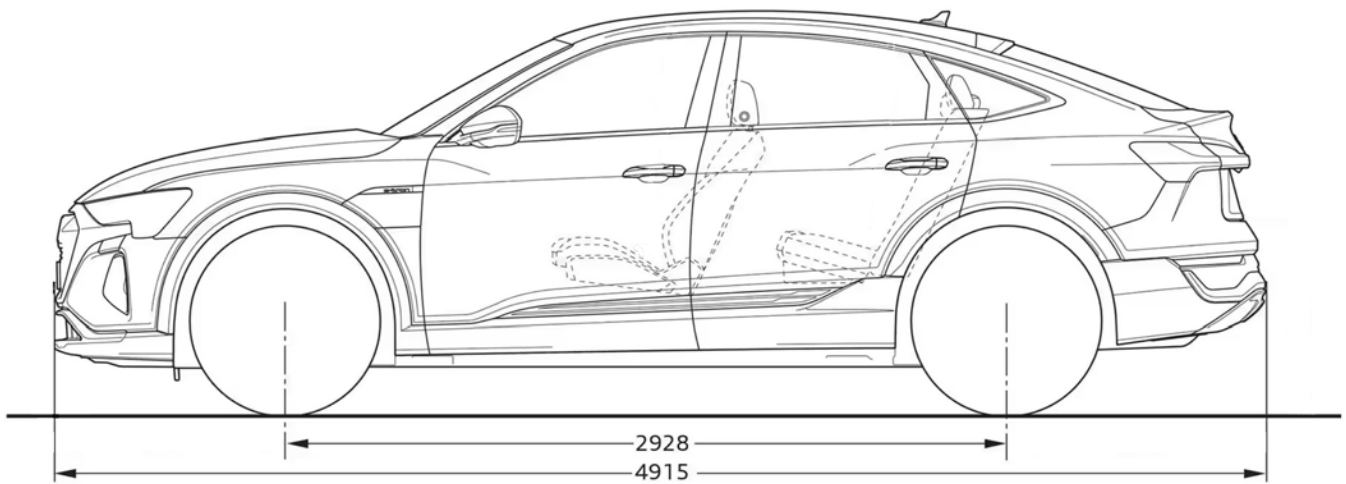
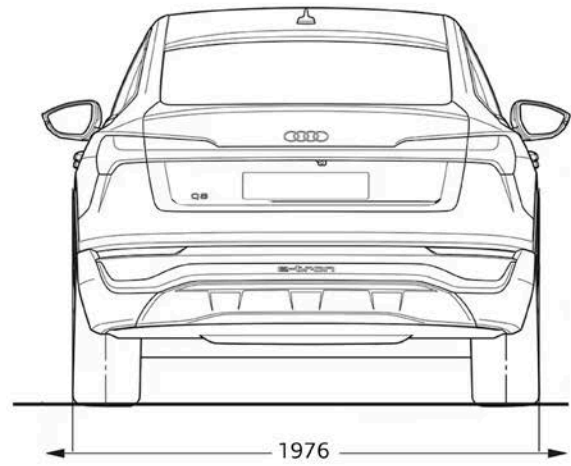
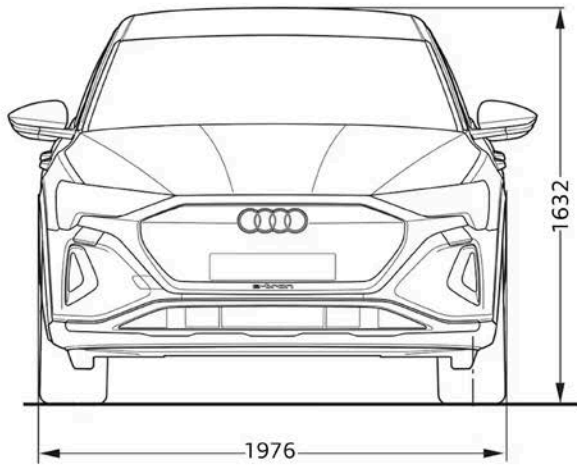

Technical details

Audi Q8 Sportback 50 e-tron

Power (hp at rpm)
340

Torque (Nm)
664

Acceleration (0-100 Kilometers per hour)
6.0

Top Speed (Kilometers per hour)
200

Drive Type
quattro

Dimensions LxWxH (mm)
4915 x 1976 x 1632

Wheel Base (mm)
2928

Audi Q8 Sportback 55 e-tron

Power (hp at rpm)
408

Torque (Nm)
664

Acceleration (0-100 Kilometers per hour)
5.6

Top Speed (Kilometers per hour)
200

Drive Type
quattro

Dimensions LxWxH (mm)
4915 x 1976 x 1632

Wheel Base (mm)
2928

Audi Vorsprung durch Technik

Audi India

A division of

ŠKODA AUTO Volkswagen

India Private Limited





Regd Office:- E1MIDC, Phase 3,

Village Nigoje, Kharab Wadi,

Chakan, Pune, Maharashtra – 410501

CIN: U70102PN2007FTC133117

www.audi.in

 audiin  Audi India  AudiIN  Audi India  Audi India | **Audi Approved :plus** | my**Audi** Connect

European vehicle model, accessories, features, equipment and vehicle configuration is shown for representation purpose only and may not be offered in India. Dark Shade on the glass is due to lighting effect. The features, specifications, accessories, colors may vary and are subject to change without any prior notice. Some of the features, accessories, services listed may not be currently offered in India. The vehicle models are equipped with optional features, for which an extra charges may be applicable. Images clicked in country that follow left hand drive. Not to be reproduced, including in part, without the written approval of Audi India (A Division of SKODA AUTO Volkswagen India Pvt. Ltd.) For further details, please contact nearest Audi authorized dealer.